

CELL ENCAPSULATION IN SMALL DOUBLE EMULSIONS

1. INTRODUCTION

The last decade has seen an exponential increase in new methods for encapsulating and analyzing single cells, revealing fundamental insights into cell diversity, tissue organization, and organismal development. This has increased the need for cell encapsulation and sorting devices that are safer, more efficient and easier to use than current technologies. In particular, droplet microfluidics has become a powerful class of cell encapsulation techniques due to its unprecedented performance and efficiency (1).

Encapsulation that isolates components from the environment is widely used in the pharmaceutical, food, and cosmetic fields to protect actives, mask the flavor, deliver and release drugs in a controlled manner. Precise control of the encapsulation characteristics of each component is critical to achieve optimal therapeutic efficacy in pharmaceutical applications (1, 2).

To carry out the cell encapsulation method, emulsions containing the cell of interest must be generated. In contrast to simple water-in-oil (w/o) emulsions, w/o/w double emulsions (DE) do not only provide aqueous compartments but also an aqueous carrier fluid, rendering the emulsion compatible with most flow cytometry and cell sorting set-ups. Encapsulation of to-be-analyzed entities in w/o/w droplet containers has further advantages: (i) shielding of sensitive biological structures from forces exerted by the sheath fluid; (ii) preservation of the linkage between an individual microorganism and the substances it secretes allowing for a screening of metabolites; and (iii) the opportunity to perform in vitro analyses of biomolecules detached from the respective microorganisms (3). Therefore, the cell encapsulation method within double emulsions represents a breakthrough in numerous applications, such as cell culture, drug delivery, transplants, and more...

To take advantage of the benefits offered by double emulsions in cell encapsulation and sorting, we must ensure the compatibility of these droplets with cell sorters. For successful sorting, DE droplets must be significantly smaller ($< 60 \mu\text{m}$ in diameter) than commercial cell sorters nozzles (typically $70\text{--}130 \mu\text{m}$ in diameter) while simultaneously large enough to encapsulate variants of interest within the inner core volume (4).

APPLICATION NOTE



Therefore, the ability to encapsulate cells in double emulsions small enough to be compatible with commercial cell sorters would be a major advance in the field of biomedical research.

Typically, double emulsions are produced in batches by a two-stage emulsification process (mixing in bulk), resulting in a highly polydisperse population with low encapsulation efficiency, which can prove to limit high-precision applications such as pharmaceuticals (3).

Compared to currently existing techniques, droplet-based microfluidic techniques offer maximum control over droplet generation. This technique enables the production of highly monodisperse double emulsions that encapsulate the internal droplets as well as the entrapped component (5).

Therefore, in this cell encapsulation method, to obtain optimal results, we use Fluidigent's fluid handling system, which provides us with continuous, fast, and highly reproducible production using Secoya's emulsification technology, the [RayDrop™](#), which is the first easy-to-use device that enables the reliable production of double emulsions. Its specific design allows for multiple liquid-type emulsification within the same device with no coating needed. Also, due to its versatility and flexibility, it allows us to control both the size of the double emulsion and the shell-to-core ratio of the emulsion.

With the [Cell encapsulation platform](#), developed and manufactured by Secoya, we demonstrate an easy-to-use and robust workflow for encapsulating large, complex cells within highly monodisperse DE droplets small enough (from 25µm up to 60µm) for high-throughput screening/cell sorting.

We demonstrate the capabilities of this method by encapsulating Human Adult Peripheral Blood Mononuclear Cells (PBMC) within highly monodisperse double emulsions.

2. HOW TO PRODUCE SMALL DOUBLE EMULSIONS?

2.1. Materials

2.1.1. Materials: Products

We use the [Cell Encapsulation platform](#) to hold all components in one place. This helps keep a nice overview, keeps the RayDrop vertically to drain the air to the top and enables continuous monitoring thanks to its horizontal microscope.

Figure 1 shows the Cell encapsulation platform, developed and manufactured by Secoya, which combines the Emulsification Technology of the [RayDrop™](#) and [Fluigent's pumping technology](#).



Figure 1. Cell Encapsulation Platform.

Emulsification technology:

- » **Droplet generator:** The RayDrop™ is used to control droplet generation. It allows the generation of the double emulsion in a single step and presents no clogging problems, thus providing a continuous and highly reproducible process.

The RayDrop™ is based on the alignment of two capillaries immersed in a pressurized chamber containing the continuous phase. The dispersed phase exits one of the capillaries through a 3D-printed nozzle, placed in front of the extraction capillary for collecting the droplets. This non-embedded implementation of an axisymmetric flow-focusing is referred to as co-flow-focusing. The advantage lies in its geometry which is leading the droplet formation and then remove all wettability issues that could appear in other microfluidic chips. This allows them to generate highly monodispersed emulsions with any kind of fluids.



- In this cell encapsulation method, we have used a RayDrop DE with a 60-120-60 configuration, which will allow us to reach the droplet size required for possible further use in cell sorters.
- Two other Raydrop configuration (30-70-60 and 30-70-45) are used to achieve different double emulsion size range

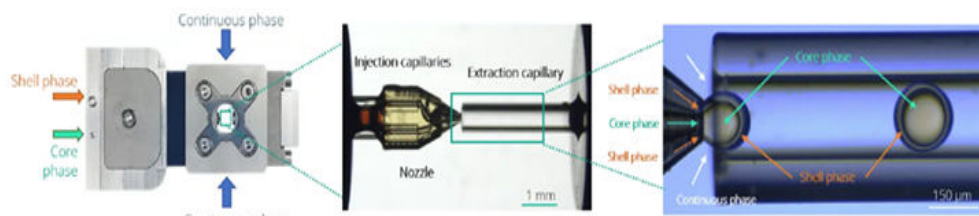

Figure 2. RayDrop Double Emulsion

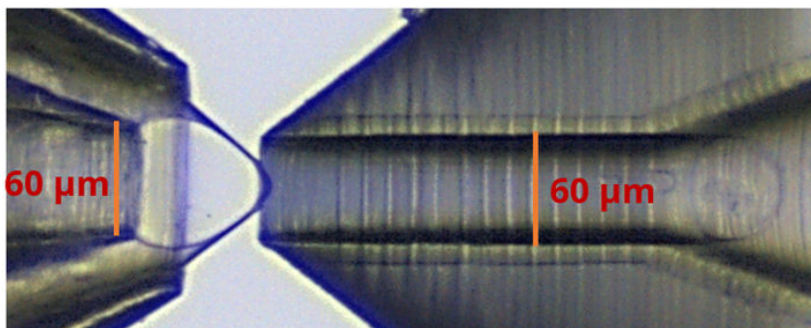

Figure 3. RayDrop Double Emulsion 60-120-60 configuration.



Fluid handling system:

- » **Microfluidic flow controller:** Our [pressure-based flow controllers](#) represent a great advantage and an alternative to traditional [syringe pumps](#), since, unlike the latter, they offer high stability, pulseless flow, fast response time, possibility to handle fluid volumes of several liters and to control fluids in dead-end channels. This high accuracy and stability allow us to perform a continuous and reproducible droplet generation process, and therefore, a cell encapsulation with high monodispersity.

The [Flow EZ](#) is the most advanced flow controller for pressure-based fluid control. It can be combined with a Flow Unit to control pressure or flow rate. It can be used without a PC. Three Flow EZ with 7 bar of full-scale pressure are used in the setup presented below.



HIGHER STABILITY

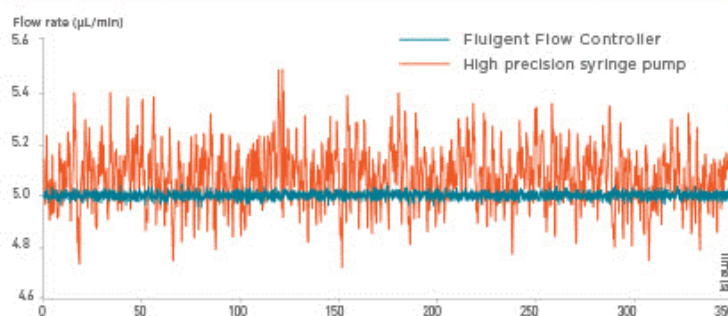

- » **Flow sensor:** The Flow Unit is a flow sensor that allows real-time flow rate measurement. By combining a Flow Unit with the Flow EZ, it is possible to switch from pressure control to flow rate control, allowing for the generation of highly monodispersed droplets over a long period of time.

Two [Flow Unit M's](#) are used here to monitor and control the flow rates of the core and shell phases while a Flow Unit L is used to control the flow rates of the continuous phase during the run.



Optical system:

- » The [Cell Encapsulation Platform](#) for cell encapsulation includes an optical system optimized for the observation of the emulsion formation inside the Raydrop. It is composed of a HI-power LED, 10x magnification and a fast camera.

APPLICATION NOTE

2.1.1. Materials: Reagents

Continuous phase:

- Water + 2% Tween20

Shell phase:

- dSurf (HFE7500 + 2% biocompatible surfactant)

Core phase:

- Water + 0.5% Fluorescein

2.2. Methods: Droplet Generation

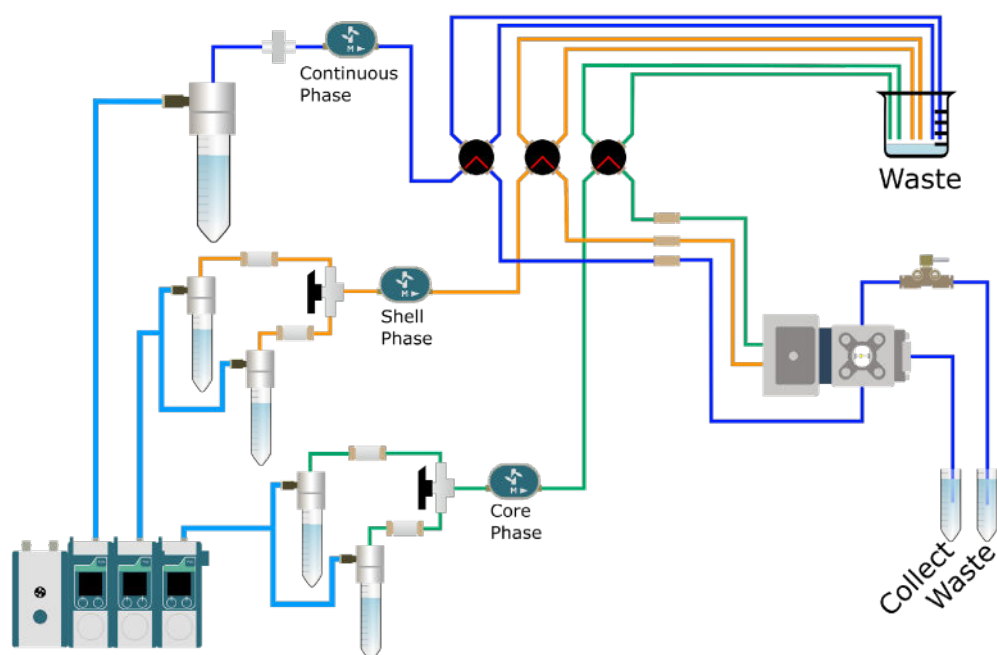

Figure 4: Setup of the Cell Encapsulation Platform.

First, the phases are filtered (pore size 0.2 μm). Then, a simple emulsion of the shell phase is produced by closing the core phase and adjusting the flow rates of the continuous phase and the shell phase.

Once the single emulsion is produced, the double emulsion process is performed by turning the core phase valve in the reservoir position towards the RayDrop™ and adjusting the flow rates.

Once an optimal and stable flow rate is reached, the production of the double emulsion is started.

After a few seconds, we can collect our droplets in their corresponding Falcon tubes for further analysis.

Visit our [protocol](#), where we detail, step by step, how to perform double emulsion generation using the Cell Encapsulation Platform.

APPLICATION NOTE

2.3. Results: Double Emulsion Production

The versatility of the RayDrop allows a wide range of sizes of monodisperse double emulsions to be achieved by changing the dimensions of the counter-nozzles or double nozzles.

With a standard 30-70 double nozzle it is possible to produce:

- Double emulsion <60 μm with a 60 μm counter nozzle.
- Double emulsion <45 μm with a 45 μm counter nozzle.

Another RayDrop configuration is also available, with a 60-120 double nozzle and a 60 μm counter nozzle for specific biological applications.

For more information, refer to section 3.3.

The size of the double emulsion produced depends on the Raydrop configuration and the flowrates of the different phases. However, for a specific Raydrop configuration, the continuous phase flowrate has the most impact on the double emulsion size. Figure 6 presents the evolution of double emulsion outer diameter produced for the three Raydrop configurations with respect to the continuous phase flowrate. Table 1 summarizes the flow rates of each phase, the outer diameters of the double emulsion and the respective coefficient of variation.

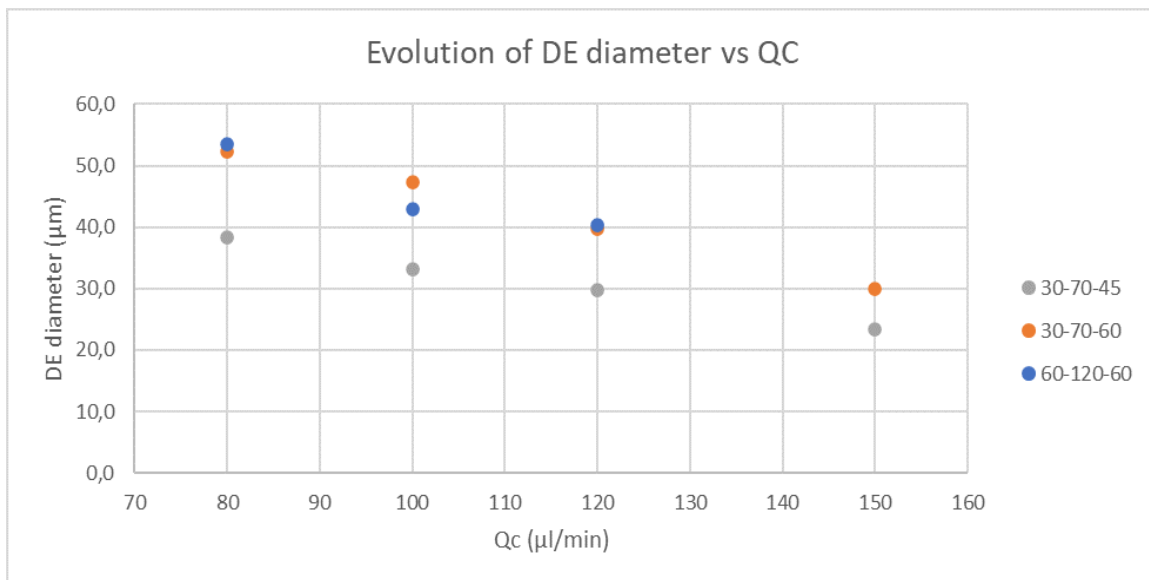

Figure 5. Influence of continuous phase flow on the diameter of double emulsions.

RayDrop	Qc μL/min	Qs μL/min	Qd μL/min	DE outside diameter μm	CV %	DE inner diameter μm	CV %
30-70-45	80	8.4	11.1	38.3	1.0	30.7	0.7
	100	7	12.6	33.2	1.0	27.8	0.6
	120	7.1	10	29.7	1.0	23.8	0.8
	150	4.3	10	23.5	1.3	19.2	1.0
30-70-60	80	11	13.4	52.4	0.7	43.8	0.6
	100	16.2	17.5	47.3	0.8	39.4	0.9
	120	13.8	15.3	39.8	1.0	32.1	1.1
	150	12.8	9.7	29.9	1.1	23.1	1.8
60-120-60	80	19.6	15.6	53.6	0.6	42.1	0.4
	100	21.4	15.3	4.3	1.1	32.5	0.8
	120	20.8	12.5	40.3	0.8	30.1	1.1

Table 1. Representation of the flow rates of each phase, outer diameters and inner diameter of the double emulsion and the respective coefficient of variation.

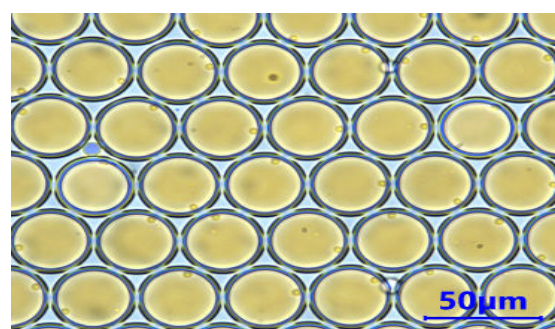
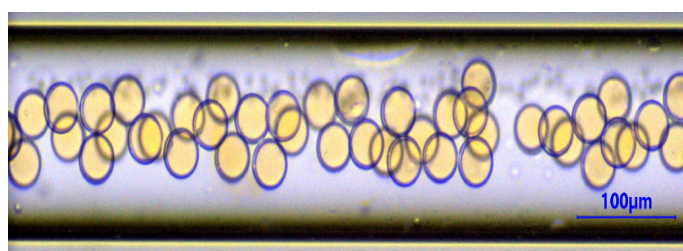

Figure 6. Fluorescein-stained double emulsions.

3. HOW TO ENCAPSULATE CELLS IN SMALL DOUBLE EMULSIONS?

3.1. Materials

3.1.1. Materials: Products

Same products as 2.1.1.

OPTIONAL MODULE: Injection Loop

The Cell Encapsulation platform with an injection loop allows users to work with samples with a reduced volume (e.g. working with cells of limited availability, such as stem cells, primary cells from patients...). It is ideal for the use of rare cells or expensive reagents with a total volume lower than 500 μ l/.

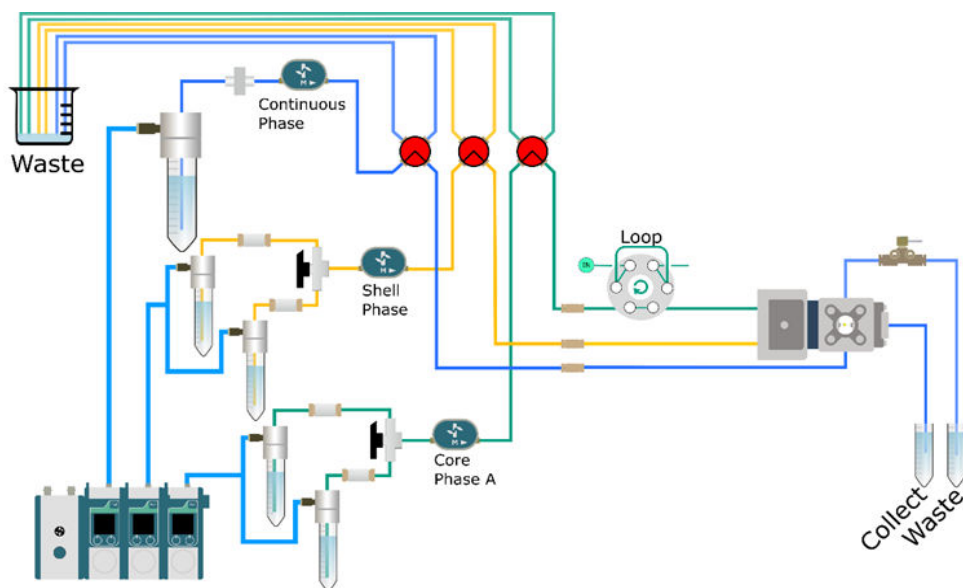

Figure 7. Cell Encapsulation platform set-up with an injection loop (L-Switch).

3.1.1. Materials: Reagents

Continuous phase:

- PBS + 2% Tween20 + 1% PEG35K + 2% Pluronic F68

Shell phase:

- dSurf (HFE7500 + 2% biocompatible surfactant)

Core phase:

- Human PBMCs stained with CellTrace violet in RPMI 1640 medium + 10 % Fetal Bovine Serum + 1% 200mM L-Glutamine + 1% Penicillin/Streptomycin

3.2. Methods: Cell encapsulation

First, the shell and core phases (pore size 0.2 μm) and the cell solution (cell strainer pore size 40 μm) are filtered and the corresponding reservoir is filled.

Then, a simple emulsion of the shell phase is produced by adjusting the flow rates of the continuous phase and the shell phase.

Once the single emulsion is produced, the cell encapsulation process is performed by turning the core phase valve in the reservoir position towards the RayDrop and adjusting the flow rate.

After a few seconds, we can collect our encapsulated cells in their corresponding Falcon tubes for further analysis.

3.3. Results: Cell encapsulation in small double emulsions

Once the cell encapsulation method is completed, the generated double emulsions are visualized under a microscope to check their monodispersity and stability.

As mentioned in section 2.3, there are several RayDropTM configurations adapted to different applications. The 30-70 double nozzles allow encapsulation of cells <10 μm in size. On the other hand, a 60-120 double nozzle allows the encapsulation of larger cells, up to <25 μm .

We used fluorescent labeling to demonstrate the chemical functionality and uniform incorporation of human PBMC cells into these double emulsions.

For this purpose, we used the Cy5 dye, the TRITC dye and the fluorescein fluorophore (FITC) to stain the entire medium in which the cells were found. Figure 7 shows that a visualization is obtained with uniform and homogeneous staining.

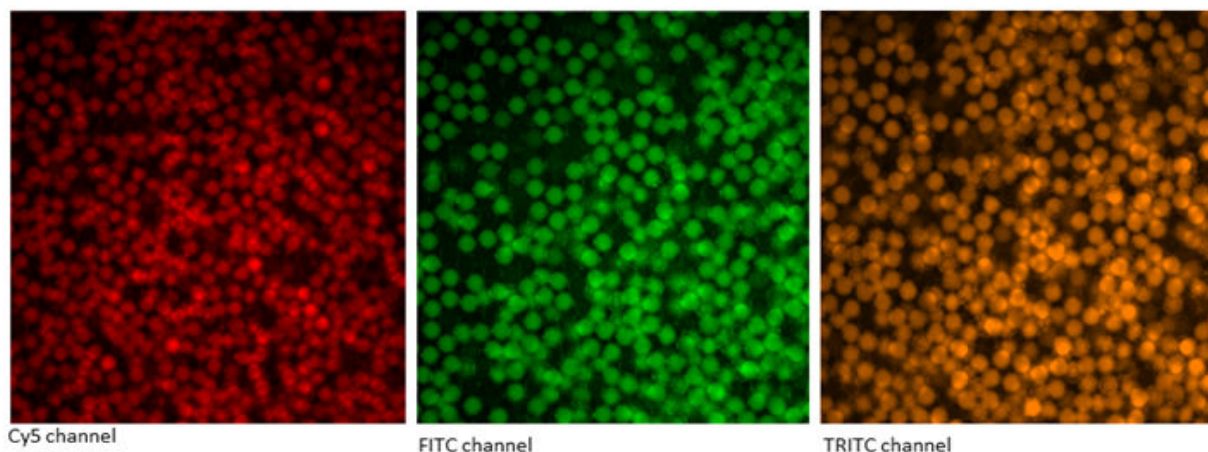

Figure 8. Staining of droplets and their respective media with different fluorophores.

Courtesy of Functional Immune Repertoire Analysis at ETH Zürich



On the other hand, CellTrace™ Violet Cell is used to both visualize the successful incorporation of cells into the droplets, and to verify the functionality of these droplets.

CellTrace™ Violet Cell is used for in vitro and in vivo labeling of cells to trace multiple generations using dye dilution by flow cytometry.

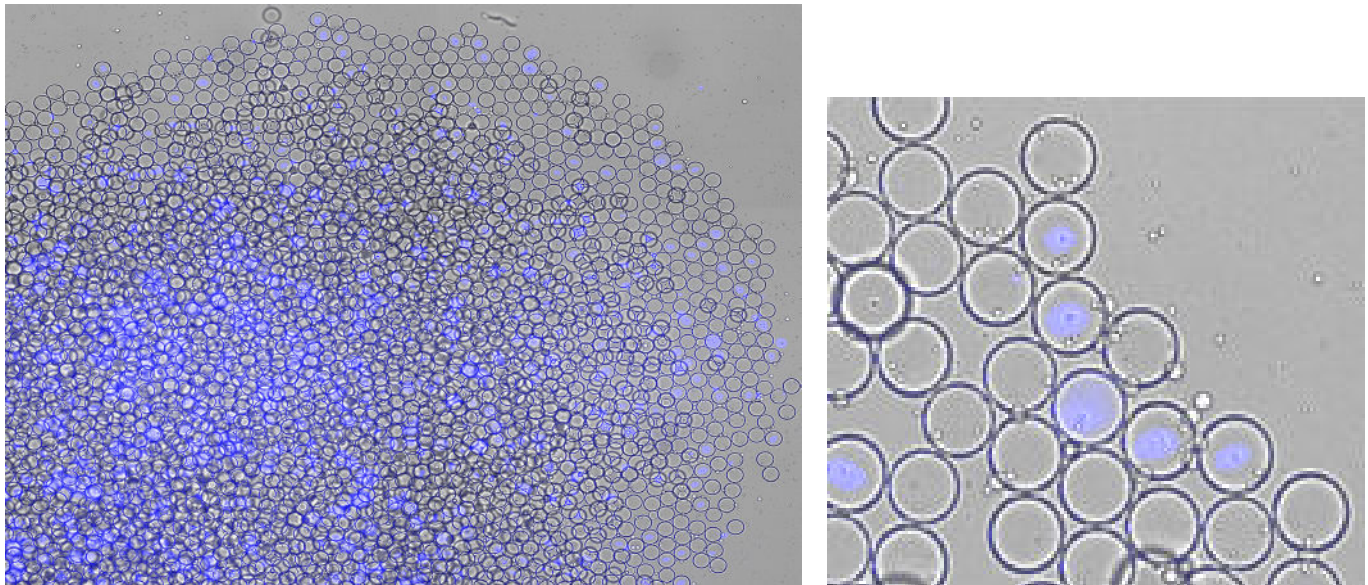

*Figure 9. DE with Human PBMCs.
CellTrace Violet, cells encapsulated (blue fluorescence).
Courtesy of Functional Immune Repertoire Analysis at ETH Zürich*

As seen in the figure 8, the droplets have uniform sizes and fluorescence intensity. The fluorescence among droplets within each fluorophore appears uniform for each condition, suggesting the uniform distribution of the fluorophore throughout each double emulsion. This result clearly illustrates the chemical functionality and uniform incorporation of fluorophores in the double emulsions. CellTrace™ Violet Cell allows us to clearly visualise those cells that have been successfully encapsulated, which confirms the great encapsulation capacity of our platform.

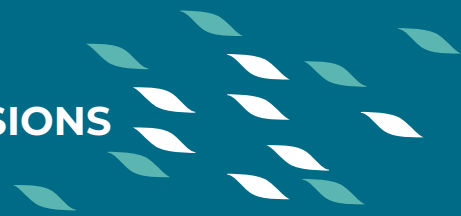

CONCLUSION

In this application note, we have demonstrated that the Raydrop is able to produce monodisperse double emulsion with an outer diameter below 60 μm . We also demonstrate that the Cell Encapsulation Platform can encapsulate cells in w/o/w double emulsion with a precise control of droplet size. Human PBMCs in RPMI 1640 were encapsulated in water-oil-water monodisperse double emulsion of 52 μm using a 60-120-60 Raydrop. Other RayDrop configurations, with different nozzle dimensions, are available to target different ranges of droplet sizes, and therefore different ranges of cell sizes. This is due to the versatility and flexibility of the RayDrop, which enables us to easily change configuration and change capillary size.



REFERENCES

1. Brower, K.K. et al. (2020) "Double emulsion picoreactors for high-throughput single-cell encapsulation and phenotyping via FACS," *Analytical Chemistry*, 92(19), pp. 13262–13270. Available at: <https://doi.org/10.1021/acs.analchem.0c02499>.
2. Wang, W., Zhang, M.-J. and Chu, L.-Y. (2014) "Microfluidic approach for encapsulation via double emulsions," *Current Opinion in Pharmacology*, 18, pp. 35–41. Available at: <https://doi.org/10.1016/j.coph.2014.08.003>.
3. Yan, J. et al. (2013) "Monodisperse water-in-oil-in-water (w/o/w) double emulsion droplets as uniform compartments for high-throughput analysis via flow cytometry," *Micromachines*, 4(4), pp. 402–413. Available at: <https://doi.org/10.3390/mi4040402>.
4. Lim, S.W. and Abate, A.R. (2013) "Ultrahigh-throughput sorting of microfluidic drops with flow cytometry," *Lab on a Chip*, 13(23), p. 4563. Available at: <https://doi.org/10.1039/c3lc50736j>.
5. Brower, K.K. et al. (2020) "Double emulsion flow cytometry with high-throughput single droplet isolation and nucleic acid recovery," *Lab on a Chip*, 20(12), pp. 2062–2074. Available at: <https://doi.org/10.1039/d0lc00261e>.

